



ZAVOD ZA
GRADBENIŠTVO
SLOVENIJE

SLOVENIAN
NATIONAL BUILDING
AND CIVIL ENGINEERING
INSTITUTE



član EOTA
Member of EOTA

Dimičeva 12
1000 Ljubljana, Slovenija

Tel.: +386 (0)1-280 44 72, 280 45 37

Fax: +386 (0)1-280 44 84

E-mail: info.ta@zag.si

http://www.zag.si

European Technical Assessment

ETA-12/0360
of 19.10.2016

English version prepared by ZAG

GENERAL PART

Organ za tehnično ocenjevanje, ki je izdal ETA
Technical Assessment Body issuing the ETA

ZAG Ljubljana

Komercialno ime gradbenega proizvoda
Trade name of the construction product

MFT Spikerplugg

Družina proizvoda

Product family to which the construction product belongs

Zabito plastično sidro za pritrjevanje toplotno izolacijskih sistemov z ometi na podlagi iz betona
Nailed-in plastic anchor for fixing of external thermal insulation composite systems with rendering in concrete

Proizvajalec
Manufacturer

**HITACHI POWER TOOLS NORWAY AS
Kjeller Vest 7
2007 KJELLER
NORWAY**

Proizvodni obrat
Manufacturing plant

**HITACHI POWER TOOLS NORWAY AS
Plant N° 1 (Italy)**

Ta Evropska tehnična ocena vsebuje

This European Technical Assessment contains

9 strani vključno s 6 prilogami, ki so sestavni del te ocene
9 pages including 6 annexes, which form an integral part of the document

Ta Evropska tehnična ocena je izdana na podlagi Uredbe (EU) št. 305/2011 na osnovi
This European Technical Assessment is issued in accordance with Regulation (EU) No 305/2011, on the basis of

Smernice za evropska tehnična soglasja ETAG 014, izdaja 2011, ki se uporablja kot EAD
Guideline for European Technical Approval ETAG 014, edition 2011, used as EAD

Ta ocena zamenjuje
This Assessment replaces

ETA-12/0360 izdano dne 21.08.2012
ETA-12/0360 issued on 21.08.2012

Translations of this European Technical Assessment in other languages shall fully correspond to the original issued document and should be identified as such.

Communication of this European Technical Assessment, including transmission by electronic means, shall be in full (excepted the confidential Annex(es) referred to above). However, partial reproduction may be made, with the written consent of the issuing Technical Assessment Body. Any partial reproduction has to be identified as such.



II SPECIFIC PART OF THE EUROPEAN TECHNICAL ASSESSMENT

1 Technical description of the product

The plastic anchor MFT Spikerplugg (TSS) - MFT Spikerplugg (TPP) - MFT Spikerplugg med stor krave (TBB) consists of a plastic expansion sleeve with a collar for fixing the profiles for thermal insulation systems and a metallic nail as an expansion element. The anchor sleeve is made of polyamide PA6. The nail is made of zinc plated steel or of stainless steel. The collar is made in three versions (countersunk, cylindrical head and large rim), whereas nail head is made in two versions (regular shape and nail screw with threaded part).

The anchor is installed in drilled hole by hammering in the expansion nail. The expansion of the anchor applies the anchorage.

The installed anchor is shown in Annex A1.

2 Specification of the intended use(s) in accordance with the applicable European Assessment Document (hereinafter EAD)

The performances given in Chapter 3 are only valid if the anchor is used in compliance with the specifications and conditions given in Annex B.

The provisions made in this European Technical Assessment are based on an assumed working life of the anchor of 25 years. The indications given on the working life cannot be interpreted as a guarantee given by the manufacturer, but are to be regarded only as a means for choosing the right products in relation to the expected economically reasonable working life of the works.

3 Performance of the product and references to the methods used for its assessment

3.1 Mechanical resistance and stability (BWR 1)

Requirements with respect to the mechanical resistance and stability of non-load bearing parts of the works are not included in this basic work requirement but are under basic work requirement safety in use.

3.2 Safety in case of fire (BWR 2)

No performance determined.

3.3 Hygiene, health and environment (BWR 3)

Regarding dangerous substances contained in this European Technical Assessment, there may be requirements applicable to the products falling within its scope (e.g. transported European legislation and national laws, regulations and administrative provisions). In order to meet provisions of the regulation (EU) No 305/2011, these requirements need also to be complied with, when they apply.

3.4 Safety in use (BWR 4)

The basic work requirements for safety in use are listed in Annex C1.

3.5 Protection against noise (BWR 5)

Not relevant.

3.6 Energy economy and heat retention (BWR 6)

Not relevant.

3.7 Sustainable use of natural resources (BWR 7)

No performance assessed.

3.8 General aspects relating to fitness for use

Durability and serviceability are only ensured if specifications of intended use according to Annexes B are kept.



4 Assessment and verification of constancy of performance (AVCP)

According to the decision 97/463/EC of the European Commission¹ the system of assessment and verification of constancy of performance (see Annex V to regulation (EU) No 305/2011) 2+ apply.

5 Technical details necessary for the implementation of the AVCP system, as provided in the applicable European Assessment Document

Technical details necessary for the implementation of the AVCP system are laid down in the Control plan deposited at the Slovenian National Building and Civil Engineering Institute (ZAG).

Issued in Ljubljana on 19.10.2016

Signed by:

Franc Capuder, M.Sc., Research Engineer

Head of Service of TAB



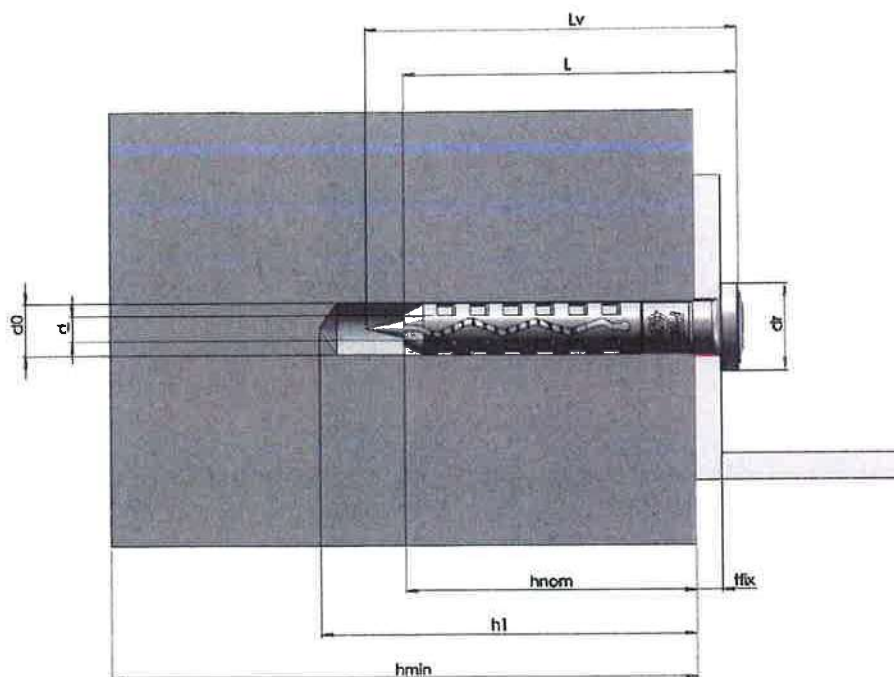

- L = total length of the plastic anchor sleeve
 d_0 = nominal diameter of drill bit (= diameter of the plug)
 h_1 = depth of drill hole
 h_{norm} = minimum embedment depth (the same of the h_{ef} = effective anchorage depth)
 d = nominal diameter of the nail screw
 L_v = total length of the nail screw
 d_r = diameter of the collar
 h_{min} = minimum thickness of the concrete member
 t_{fix} = thickness of fixture (the maximum thickness is inclusive of any non-structural layer of plaster)

MFT Spikerplugg

Product description

Installed condition

Annex A1





Table A1: Different sizes and combinations of plastic sleeves and steel nails

Type	Description	Schema
MFT Spikerplugg (TSS)	Countersunk head + nail screw	
	Countersunk head + nail screw with threaded part	
MFT Spikerplugg (TPP)	Cylindrical head + nail screw	
MFT Spikerplugg med stor krave (TBB)	Large rim + nail screw	

MFT Spikerplugg

Product description

Different components of the anchor: sleeves and nails

Annex A2



Table A2: Dimensions of components

Anchor type $d_0 \times L$	Diameter of anchor sleeve d_0 [mm]	Diameter of the nail d [mm]	Length of an anchor L_v [mm]	Diameter of the collar d_r [mm]	External thread
MFT Spikerplugg (TSS) Countersunk head + nail screw					
6x40	6	3,8	45	10	-
6x50			55		
6x60			65		
6x80			85		
8x60	8	4,8	65	12	-
8x80			85		
8x100			105		
8x120			125		
8x140			145		
MFT Spikerplugg (TSS) Countersunk head + nail screw with threaded part					
6x40	6	3,8	45	10	M6x6
6x50			55		M6x6
6x40			45		M7x6
6x50			55		M7x6
MFT Spikerplugg (TPP) Cylindrical head + nail screw					
6x40	6	3,8	45	10	-
6x50			55		
6x60			65		
8x60	8	4,8	65	11,5	-
8x80			85		
8x100			105		
8x120			125		
8x140			145		
MFT Spikerplugg med stor krave (TBB) Large rim + nail screw					
6x40	6	3,8	45	13	-
6x50			55		
6x60			65		
8x80	8	4,8	85	15	-
8x100			105		
8x120			125		
8x140			145		
8x160			165		

Table A3: Materials

	Materials
Anchor sleeve	Polyamide Pa6 acc. to ISO 1874
Nail	Steel grade 5.8 zinc plated A2K acc. to ISO 4042 or Stainless Steel A2-50 wr. 1.4567 or 1.4301 or 1.4306 acc. to EN 10088-3

MFT Spikerplugg**Product description**

Dimensions and materials

Annex A3



Specifications of intended use

Anchorage subject to:

- The anchor shall only be used for the transmission of wind suction loads and shall not be used for the transmission of dead loads of thermal insulation composite system. The dead loads have to be transmitted by the bonding of the thermal insulation composite system.

Base materials:

- Normal weight concrete C16/20 to C50/60 (use category A) according Annex C1;

Application temperature range:

- 5°C to +40°C (maximum short term temperature +40°C and maximum long term temperature +24°C).

Design:

- The design of anchorages is carried out in compliance with ETAG 014 "Guideline for European Technical Approval of Plastic Anchors for Fixing of External Thermal Insulation Composite System with Rendering" under the responsibility of the engineer experienced in anchorages.
- Verifiable calculation notes and drawings shall be prepared taking account of the loads to be anchored. The position of the anchor shall be indicated on the design drawings.
- Fasteners are only to be used for multiple non-structural application, according to ETAG 014, Edition February 2011.

Installation:

- Use of hammer drilling method.
- Anchor installation carried out by appropriately qualified personnel and under the supervision of the person responsible for technical matters on the site.
- Ambient temperature during the installation of the anchor 5°C to 40°C.
- Exposure to UV due to solar radiation of the anchor not protected by rendering ≤ 6 weeks.

MFT Spikerplugg	Annex B1 
Intended use Specification	

Table B1: Installation parameters

Anchor type $d_0 \times L$	Nominal drill bit diameter d_0 [mm]	Thickness of the fixture t_{fix} [mm]	Depth of drilled hole to deepest point h_1 [mm]	Embedment depth h_{nom} [mm]
MFT Spikerplugg (TSS) Countersunk head + nail screw				
6x40	6	10	40	30
6x50		20		
6x60		30		
6x80		50		
8x60	8	20	50	40
8x80		40		
8x100		60		
8x120		80		
8x140		100		
MFT Spikerplugg (TSS) Countersunk head + nail screw with threaded part				
6x40	6	-	50	40
6x50		-	60	50
6x40		-	50	40
6x50		-	60	50
MFT Spikerplugg (TPP) Cylindrical head + nail screw				
6x40	6	10	40	30
6x50		20		
6x60		30		
8x60	8	20	50	40
8x80		40		
8x100		60		
8x120		80		
8x140		100		
MFT Spikerplugg med stor krave (TBB) Large rim + nail screw				
6x40	6	10	40	30
6x50		20		
6x60		30		
8x80	8	40	50	40
8x100		60		
8x120		80		
8x140		100		
8x160		120		

Table B2: Minimum spacing and edge distances, dimension of members

Minimum spacing	$s_{min} =$ [mm]	100
Minimum edge distance	$c_{min} =$ [mm]	100
Minimum thickness of member	$h_{min} =$ [mm]	100

MFT Spikerplugg**Intended use**

Installation parameters, minimum thickness,
edge distance and spacing

Annex B2



Table C1: Characteristic resistance to tension loads $N_{Rk,p}$ in concrete for a single anchor in kN

Base material	Characteristic resistance to tension loads $N_{Rk,p}$ [kN]	
	M6	M8
Concrete C 16/20 to C 50/60 (EN 206-1)	1,2	
Partial safety factor $\gamma_M^{(1)}$	2,0	

¹⁾ in absence of other regulations, see ETAG 014 point 7.1

Table C2: Displacements under tension load N

Base material	Tension load N [kN]		Displacement δ_m (N) [mm]	
	M6	M8	M6	M8
	Concrete C16/20 to C50/60 (EN 206-1)	0,40	0,40	0,20

MFT Spikerplugg

Performance

Characteristic resistance and displacements

Annex C1

