

ELECTRIC TOOL PARTS LIST

CORDLESS IMPACT DRIVER DRILL 2010-12-14 Model DV 18DBL (E1)

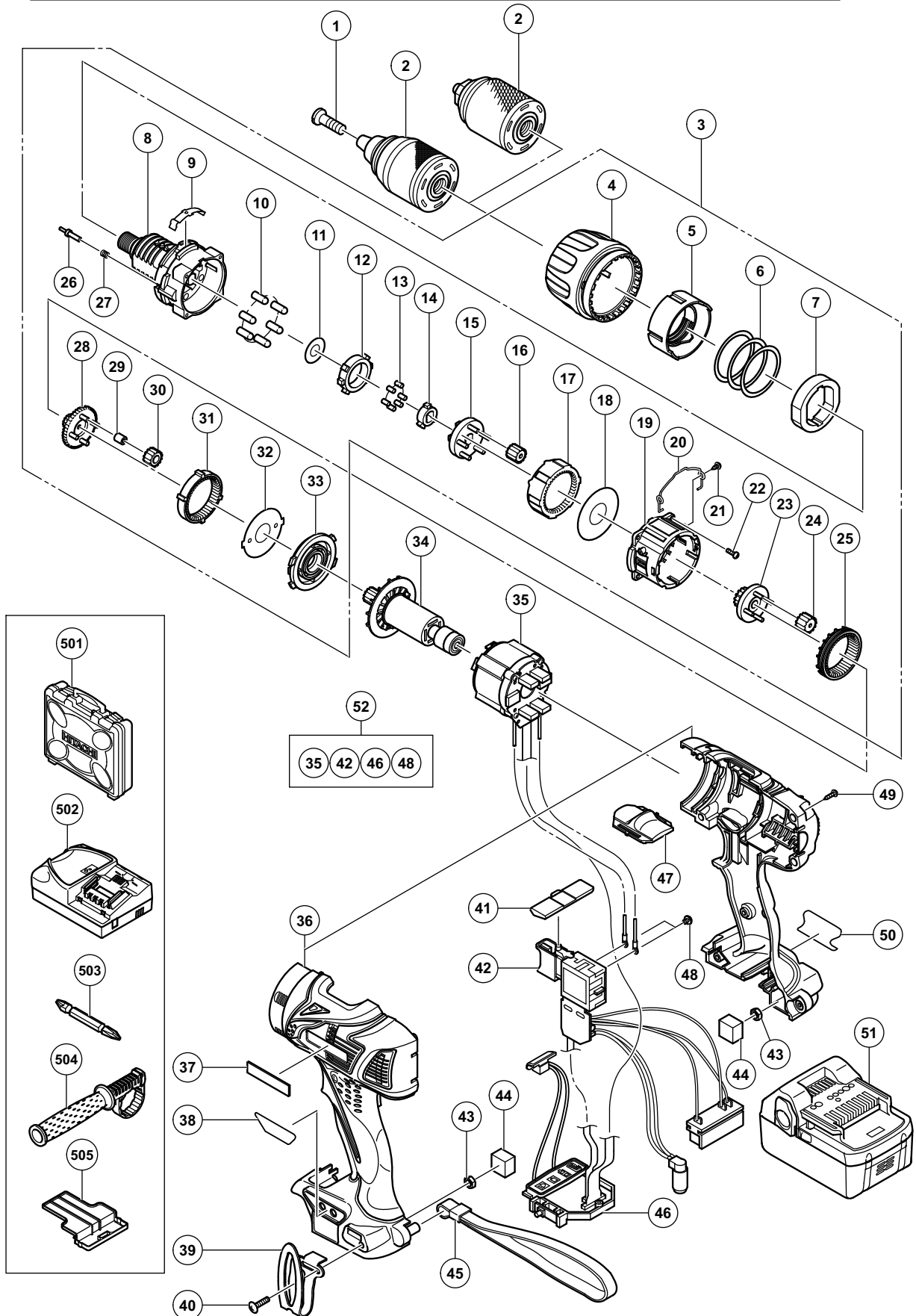

PARTS

DV 18DBL

ITEM NO.	CODE NO.	DESCRIPTION	NO. USED	REMARKS
1	995-344	FLAT HD. SCREW (A) (LEFT HAND) M6 X 25	1	
* 2	331-914	DRILL CHUCK 13VLRN-N (W/O CHUCK WRENCH)	1	
* 2	333-691	DRILL CHUCK 13VLRK-N (W/O CHUCK WRENCH)	1	FOR EUROPE
3	333-435	GEAR BOX ASS'Y	1	INCLUD. 4-33
4	333-511	FRONT CAP	1	
5	333-512	NUT	1	
6	333-513	SPRING	1	
7	333-514	SLEEVE	1	
8	333-515	FRONT CASE	1	
9	333-516	CLICK SPRING	1	
10	333-539	PIN SET (6 PCS.)	6	
11	331-909	WASHER (A)	1	
12	331-903	LOCK RING (A)	1	
13	331-888	NEEDLE ROLLER SET (6PCS.)	6	
14	331-904	LOCK CAM	1	
15	333-517	CARRIER	1	
16	333-518	PLANET GEAR (C) SET (5 PCS.)	5	
17	333-519	RING GEAR	1	
18	331-892	WASHER (A)	1	
19	331-893	REAR CASE	1	
20	331-894	SHIFT ARM	1	
21	330-579	SCREW SET D2 X 3.5 (2 PCS.)	2	
22	320-087	SCREW SET M3 X 12 (4 PCS.)	4	
23	331-897	PINION (C)	1	
24	333-520	PLANET GEAR (B) SET (4 PCS.)	4	
25	333-521	SLIDE RING GEAR	1	
26	333-522	STOPPER (A)	2	
27	333-523	STOPPER SPRING	2	
28	333-524	PINION (B)	1	
29	331-926	NEEDLE BEARING SET (4 PCS.)	4	
30	333-525	PLANET GEAR (A) SET (4 PCS.)	4	
31	333-526	FIRST RING GEAR	1	
32	322-988	WASHER (B)	1	
33	331-902	MOTOR SPACER	1	
34	333-528	ROTOR PINION SET	1	
35	340-765	STATOR FET PCB	1	
36	331-711	HOUSING (A). (B) SET	1	
37	329-648	HITACHI PLATE	1	
38	330-662	PANEL SHEET (B)	1	
39	332-824	HOOK	1	
40	327-001	TRUSS HD. SCREW M4 (BLACK)	1	
41	331-907	PUSHING BUTTON	1	
42	331-715	DC-SPEED CONTROL SWITCH	1	
43	327-002	LOCK NUT M4 (BLACK)	2	
44	330-854	PACKING	2	
45	306-952	STRAP (BLACK)	1	
46	333-689	CONTROLLER	1	
47	331-908	SHIFT KNOB	1	
48	994-532	MACHINE SCREW (W/SP. WASHER) M3 X 5	2	
49	313-687	TAPPING SCREW (W/FLANGE) D3 X 16 (BLACK)	9	

PARTS

DV 18DBL

ITEM NO.	CODE NO.	DESCRIPTION	NO. USED	REMARKS
50		NAME PLATE	1	
51	329-083	BATTERY BSL 1430 (EUROPE, AUS, NZL)	2	INCLUD. 505
52	333-436	WIRING ASS'Y	1	INCLUD. 35, 42, 46, 48

STANDARD ACCESSORIES

ITEM NO.	CODE NO.	DESCRIPTION	NO. USED	REMARKS
501	323-230	CASE	1	
502		CHARGER (MODEL UC 18YRSL)	1	
503	983-006	+ DRIVER BIT NO.2 65L	1	
504	331-906	SIDE HANDLE	1	
505	329-897	BATTERY COVER	1	

OPTIONAL ACCESSORIES

ITEM NO.	CODE NO.	DESCRIPTION	NO. USED	REMARKS
601	955-657	- DRIVER BIT (A) 3MM X 70L	1	
602	955-659	- DRIVER BIT (A) 4MM X 70L	1	
603	955-674	- DRIVER BIT (A) 6MM X 70L	1	
604	983-004	+ DRIVER BIT NO.1 65L	1	
605	983-011	+ DRIVER BIT NO.3 65L	1	